



INSTALLATION, OPERATION & APPLICATION GUIDE

For more information on our complete range of American-made products – plus wiring diagrams, troubleshooting tips and more, visit us at www.icmcontrols.com



CONNECTIONS

1. Remove power from system.
2. Connect 3-phase input wires to Line 1, Line 2, Line 3 terminals.
3. Connect motor (load) wires to Load 1, Load 2, and Load 3 terminals.
4. Make 24 VAC connection, probe and HP connections.
5. Verify wiring is correct.
6. Power up system and check operations.

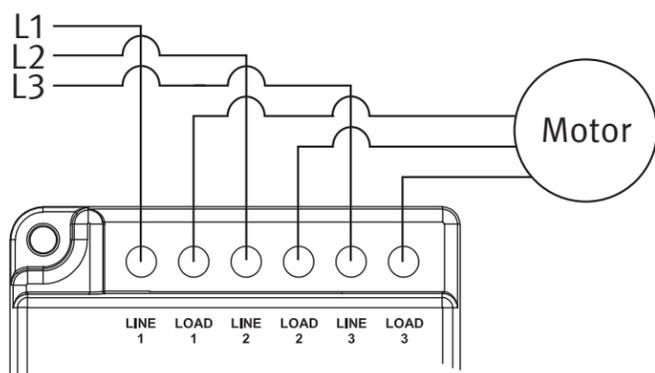

CONNECTIONS FOR AIR CONDITIONING ONLY

1. For non-heat pump applications, the heat pump select jumper must be in the Default (N.O.) position, and the REV. VALVE terminal must be left unconnected.

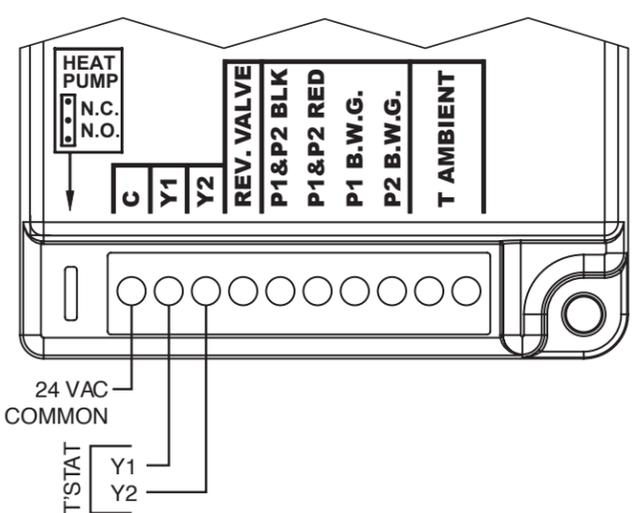

CAUTION!

Installation of the ICM334 shall be performed by trained technicians only. Adhere to all local and national electric codes.

DISCONNECT ALL POWER TO THE SYSTEM BEFORE MAKING ANY CONNECTIONS.

SPECIFICATIONS

- Line Voltage: 120 - 600 VAC
- Maximum Load Current: 10A
- Control Voltage: 18 - 30 VAC
- Frequency: 50-60 Hz
- Operating Temperature: -40°F to +140°F (-40°C to +60°C)
- Probes:
 - Temperature Sensors: P/N ICM379
 - Pressure transducer: P/N ICM380
- Reversing Valve: 24 VAC Nominal
- Heat Pump Override: 24 VAC N.C. or N.O.
- Weight: 12 ounces (341 grams)
- Mounting:
 - Surface mount using (2) #8 screws
 - The ICM334 should be surface mounted to a clean metal or other thermally conductive surface for maximum heat dissipation
 - It is recommended that the ICM334 be mounted away from the condenser exhaust air in order to maintain lower operating temperatures

INSTALLING AND CONNECTING THE SENSORS

1. Up to two transducers can be used, in which case the control will respond to the transducer that senses the highest pressure.
2. Install the pressure sensor on the discharge line transducer fitting.
3. Install the ambient temperature sensor at the T AMBIENT terminals and allow it to measure outdoor air temperature.
4. When using the temperature probe instead of a transducer, install the temperature probe several bends into the condenser. It can be attached to the U-bend or placed between the fins in the upper 1/3 of the condenser.

NOTE: The response of the system can be fine-tuned by repositioning the probe. Place the probe on the condenser where it is 100°F when pressures are correct for best response.

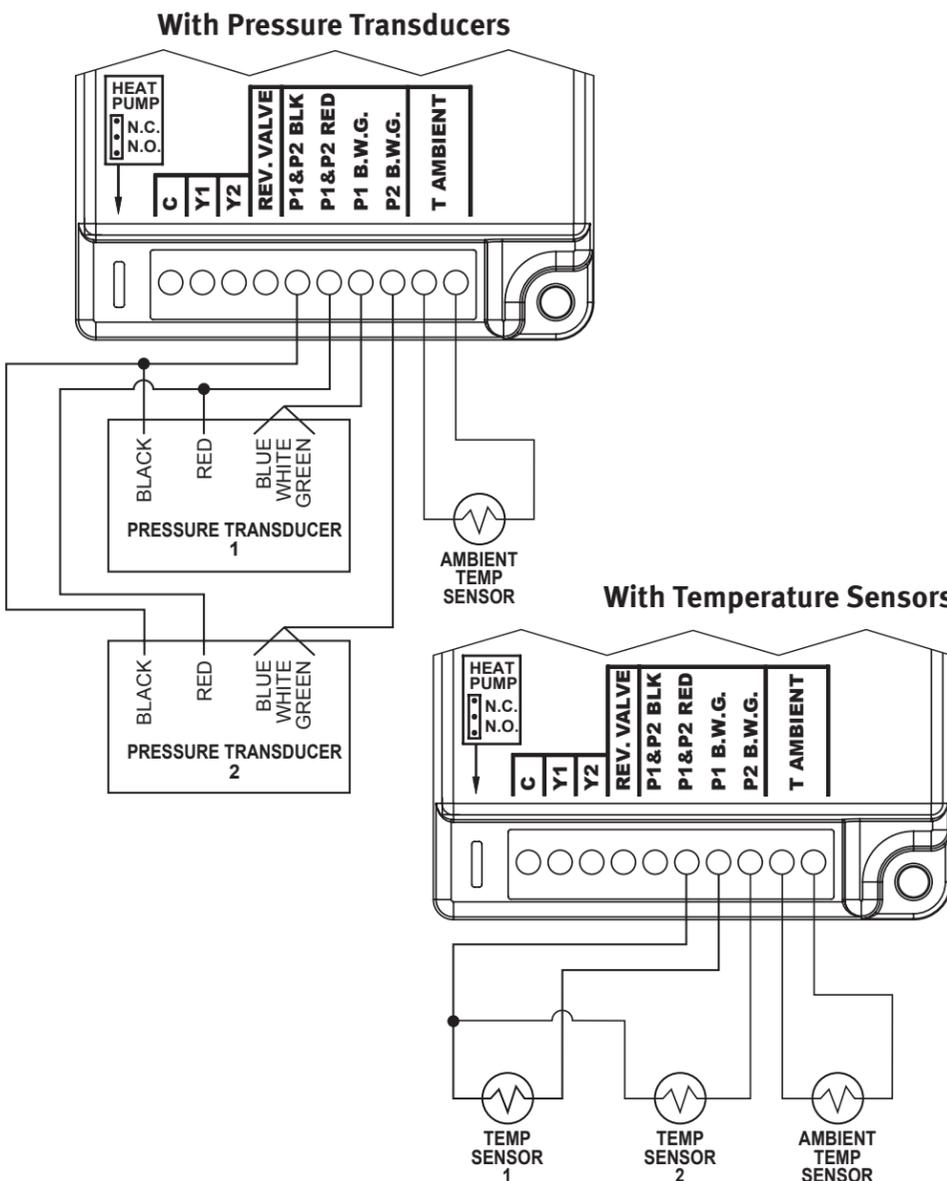

CONNECTIONS FOR HEAT PUMP SYSTEMS

1. The **REV. VALVE** terminal accepts the **24 VAC** signal from the reversing valve holding coil. Make a parallel connection from the reversing valve to the **REV. VALVE** terminal.

***Note: Do not apply a voltage higher than 30 VAC to the REV. VALVE** terminal.

2. If the **Heat Pump** is in the **Heating** mode and the reversing valve is energized, then the **Heat Pump Select** jumper must be in the **Default (N.O.)** position.

3. If the **Heat Pump** is in the **Heating** mode and the reversing valve is not energized, then the **Heat Pump Select** jumper must be in the **N.C.** position.

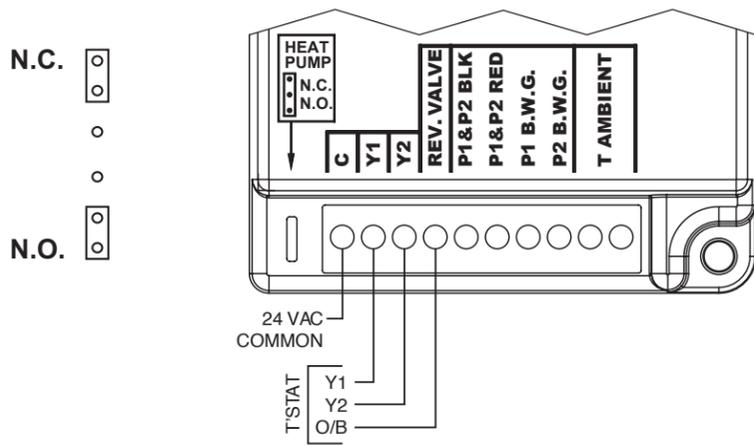

MODE OF OPERATIONS

After properly installing the **ICM334**, the three phase motor switch will control a connected motor. Using a temperature sensor and two pressure sensors, the device will monitor the ambient temperature and pressure inside the system. The monitor will be energized when there is a Y call.

When the ambient temperature is above 50°F (10°C), the motor will be energized continuously. When the ambient temperature is below 50°F, the pressure sensor is used to determine whether the motor is turned on or off. When the pressure is 15 psi below the set pressure, according to the highest reading of the two pressure sensors, the motor will be turned off. When the pressure is 15 psi above the set pressure, according to the highest reading of the two pressure sensors, the motor will be turned on.

When there is a new Y call the load will energize for 10 seconds (hard start).

APPENDIX

APPENDIX A

Temperature vs. Probe Resistance

| °C | °F | Resistance (KΩ) |
|-----|------|-----------------|
| 0° | 32° | 32.7 |
| 5° | 41° | 25.4 |
| 10° | 50° | 19.9 |
| 15° | 59° | 15.7 |
| 20° | 68° | 12.5 |
| 25° | 77° | 10.0 |
| 30° | 86° | 8.1 |
| 35° | 95° | 6.5 |
| 40° | 104° | 5.3 |
| 45° | 113° | 4.4 |
| 50° | 122° | 3.6 |

APPENDIX B

Pressure vs. Voltage

| Pressure (psig) | Voltage (Vdc) |
|-----------------|---------------|
| 0 | 0.5 |
| 50 | 0.9 |
| 100 | 1.3 |
| 150 | 1.7 |
| 200 | 2.1 |
| 250 | 2.5 |
| 300 | 2.9 |
| 350 | 3.3 |
| 400 | 3.7 |
| 450 | 4.1 |
| 500 | 4.5 |

FAULT CODES

Continuous On – Status normal

Continuous Off – Check for 24 VAC power at Y1 or Y2 with respect to C

1 – Y1 call, pressure transducer 1 fault.

Verify: sensor is connected to P1, and the correct transducer output using appendix B.

2 – Y2 call, pressure transducer 2 fault.

Verify: sensor is connected to P2, and the correct transducer output using appendix B.

3 – Ambient temperature sensor not connected or open.

TROUBLESHOOTING

| Symptom | Problem |
|--|--|
| Unit fails to start | Using an AC voltmeter, measure the voltage between Y1 or Y2 and C terminals – it should read 24 volts. Measure the line voltage between LINE1 to LINE2, LINE2 to LINE3, LINE1 to LINE3, to confirm that line voltage is present |
| The fuse is blown and/or signs of damage on the unit | The unit has been miswired and may be permanently damaged. |
| Fan ON constantly | If lights are flashing then no probe is connected or probe malfunction has occurred. See Fault Codes and measure the appropriate sensor. Check wiring of REV.VALVE/heat pump jumper. Measuring the thermistor - Disconnect the ambient temperature sensor and use an ohm meter to measure the resistance between the wires, it should match Appendix A. Measuring the pressure transducer - With power applied to the control. Use a volt meter to measure DC voltage between P1 & P2 BLK and P1B.W.G (or P2B.W.G), it should match Appendix B. |
| The high pressure switch trips off | See Unit fails to start above Check the setpoint and reduce it if needed |

ONE-YEAR LIMITED WARRANTY

The Seller warrants its products against defects in material or workmanship for a period of one (1) year from the date of manufacture. The liability of the Seller is limited, at its option, to repair, replace or issue a non-case credit for the purchase prices of the goods which are provided to be defective. The warranty and remedies set forth herein do not apply to any goods or parts thereof which have been subjected to misuse including any use or application in violation of the Seller's instructions, neglect, tampering, improper storage, incorrect installation or servicing not performed by the Seller. In order to permit the Seller to properly administer the warranty, the Buyer shall: 1) Notify the Seller promptly of any claim, submitting date code information or any other pertinent data as requested by the Seller. 2) Permit the Seller to inspect and test the product claimed to be defective. Items claimed to be defective and are determined by Seller to be non-defective are subject to a \$30.00 per hour inspection fee. This warranty constitutes the Seller's sole liability hereunder and is in lieu of any other warranty expressed, implied or statutory. Unless otherwise stated in writing, Seller makes no warranty that the goods depicted or described herein are fit for any particular purpose.

